

**XTC****XTC 24V ELECTRONIC PALLET TRUCK**

Essential for the goods transport in big warehouses and for the movement with speed during long ways.

**STANDARD EQUIPMENT**

Electronic 24V separate excitation system with energy feedback braking  
 24V 160AH traction battery  
 Electronic 24V 30A battery charger with microprocessor  
 Fixed forks 1150 mm. long  
 200 mm. lifting  
 Folding footboard with lateral protections  
 Push-button forks controls  
 Proof-seal bearings and pins with selflubricating sintered bushings  
 Double swinging front rollers  
 Electric limit switch  
 Electromagnetic parking brake  
 Protection fuse  
 Shock absorber on driving-wheel  
 Ignition switch with key  
 Chromed oleodynamic piston  
 Emergency push-button  
 Safety push-button for accident prevention  
 Stabilising wheels with extra-heavy brackets  
 Manual release of traction group  
 Acoustic warning signal  
 Battery discharged warning indicator  
 Shock resistant ergonomic steering rudder  
 Steering with gas spring for the controls release in vertical position



XTC

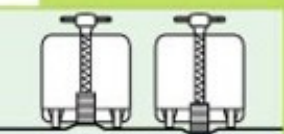

The trucks are fitted with a shock absorber system that ensures perfect contact of the driving wheel with the floor, even in the case of deep bumps.



INOX AVAILABLE

model	XTC 1502	XTC 2002	XTC 2502	XTC 3002
Q kg	1500	2000	2500	3000
C mm	600	600	600	600
I mm	1150	1150	1150	1150
L mm	1705	1705	1705	1785
X mm	180	180	180	180
X2 mm	190	190	190	190
Y mm	1335	1335	1335	1335
L2 mm	555	555	555	555
M mm	540	540	540	540
N mm	170	170	170	170
h1 mm	1030	1030	1030	1030
h3 mm	200	200	200	200
B mm	750	750	750	750
WA* mm	1670	1670	1670	1670
WA** mm	1990	1990	1990	1990

\* Closed folding footboard \*\* Open folding footboard

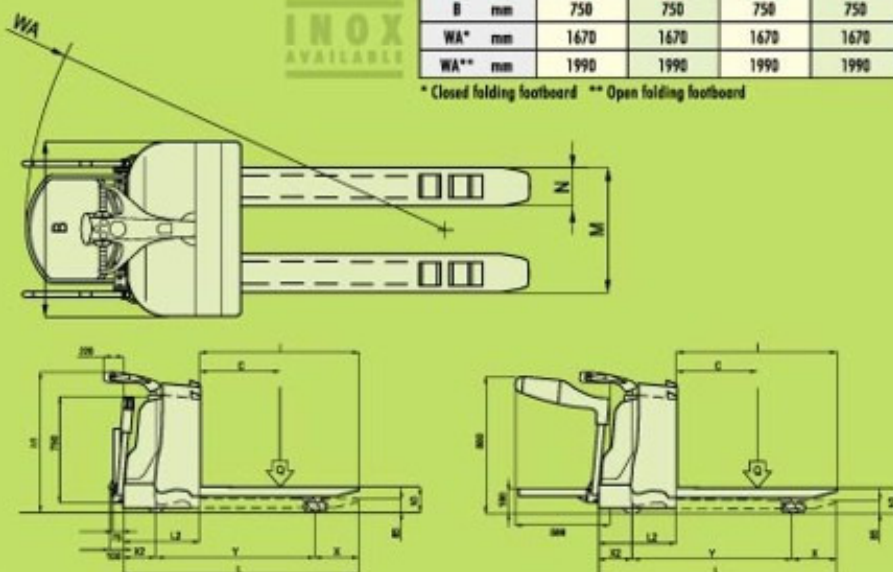

L I F T T R U C K S